

ファインU-ナット寸法表

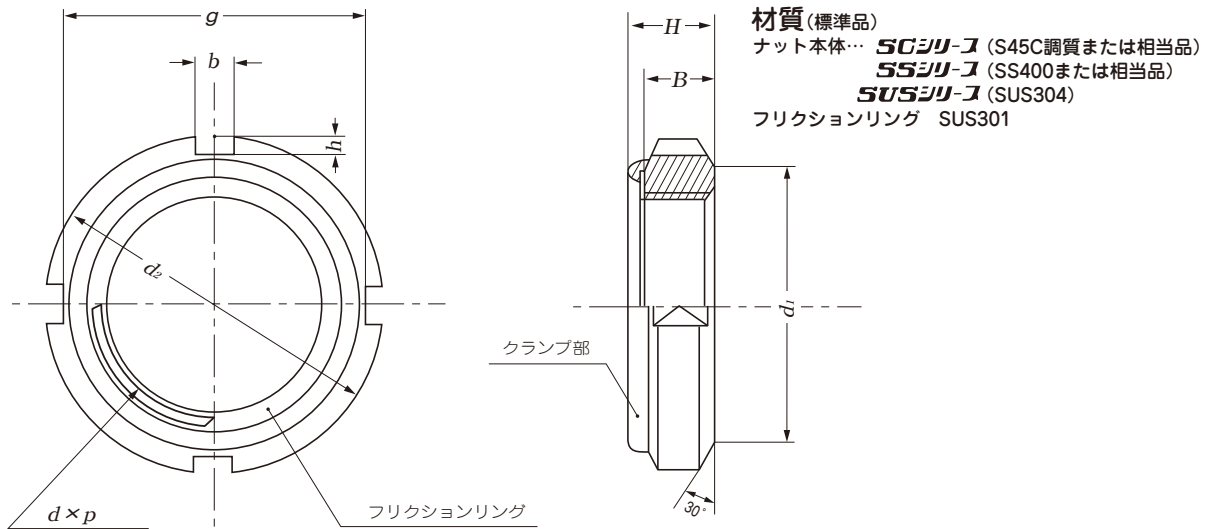

ねじ精度：JIS6H (2級) 単位：mm

品番			ねじの呼び $d \times p$	d_1	d_2	H	B	b	h	g	端面の 直角度 (最大)
SCシリーズ (材質:S45C調質)	SSシリーズ (材質:SS相当)	SUSシリーズ (材質:SUS304)									
—	FUミニSS	—	M 8×0.75	12	16	5.3	4.3	3	1.5	13	0.05
FU00SC	FU00SS	FU00SUS	M 10×0.75	13.5	18	5.2 ±0.3	4	3	1.8	14.4	
FU01SC	FU01SS	FU01SUS	M 12×1	17	22	5.4	4	3	1.8	18.4	
FU02SC	FU02SS	FU02SUS	M 15×1	21	25	6.5	5	4	1.8	21.4	
FU03SC	FU03SS	FU03SUS	M 17×1	24	28	6.4 ±0.5	5	4	1.9	24.2	
FU04SC	FU04SS	FU04SUS	M 20×1	26	32	7.7	6	4	1.8	28.4	
FU05SC	FU05SS	FU05SUS	M 25×1.5	32	38	9.1	7	5	2	34	
FU06SC	FU06SS	FU06SUS	M 30×1.5	38	45	9.1	7	5	2	41	
FU07SC	FU07SS	FU07SUS	M 35×1.5	44	52	10.2 ±0.8	8	5	2	48	
FU08SC	FU08SS	FU08SUS	M 40×1.5	50	58	11.2	9	6 ±0.2	2.5	53	
FU09SC	FU09SS	FU09SUS	M 45×1.5	56	65	12.5	10	6	2.5	60	
FU10SC	FU10SS	FU10SUS	M 50×1.5	61	70	13.5 ±1.0	11	6	2.5	65	
FU11SC	FU11SS	FU11SUS	M 55×2	67	75	13.5	11	7	3	69	
FU12SC	FU12SS	FU12SUS	M 60×2	73	80	13.5	11	7	3	74	
FU13SC	FU13SS	FU13SUS	M 65×2	79	85	15	12	7	3	79	
FU14SC	FU14SS	FU14SUS	M 70×2	85	92	15	12	8	3.5	85	
FU15SC	FU15SS	FU15SUS	M 75×2	90	98	15.8 ±0.5	13	8	3.5	91	
FU16SC	FU16SS	FU16SUS	M 80×2	95	105	18.6	15	8	3.5	98	
FU17SC	FU17SS	FU17SUS	M 85×2	102	110	19.2	16	8	3.5	103	
FU18SC	FU18SS	FU18SUS	M 90×2	108	120	20.3	16	10	4	112	
FU19SC	FU19SS	FU19SUS	M 95×2	113	125	21.3 ±1.5	17	10	4	117	
FU20SC	FU20SS	FU20SUS	M100×2	120	130	22.3	18	10	4	122	
FU21SC	—	—	M105×2	126	140	22.3	18	12	5	130	
FU22SC	—	—	M110×2	133	145	23.3	19	12	5	135	
FU23SC	—	—	M115×2	137	150	23.3	19	12	5	140	
FU24SC	—	—	M120×2	138	155	24.3 ±0.75	20	12 ±0.3	5	145	
FU25SC	—	—	M125×2	148	160	25.4	21	12	5	150	
FU26SC	—	—	M130×2	149	165	25.4	21	12	5	155	
FU27SC	—	—	M135×2	160	175	26.6	22	14	6	163	
FU28SC	—	—	M140×2	160	180	26.6 ±2.0	22	14	6	168	
FU29SC	—	—	M145×2	171	190	28.6	24	14	6	178	
FU30SC	—	—	M150×2	171	195	28.3	24	14	6	183	

(ご注文は、品番でご指示下さい)

※改良のため、寸法変更する場合があります。