

ALKO 艾奥珂

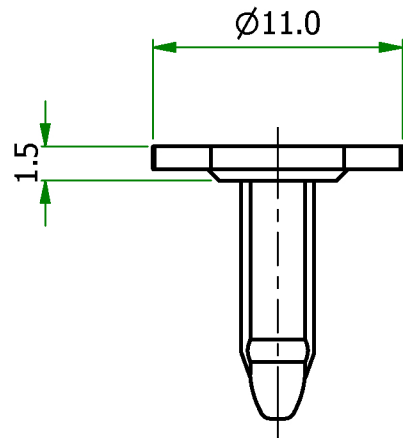

PIN

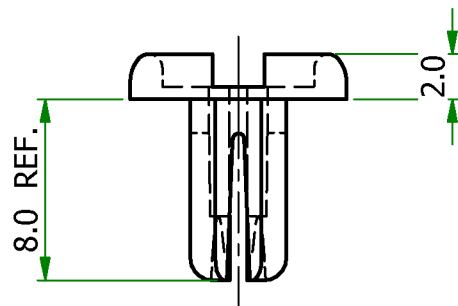
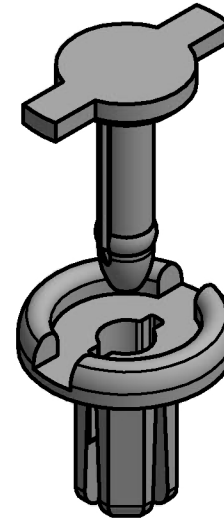
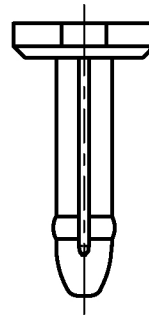

GROMMET

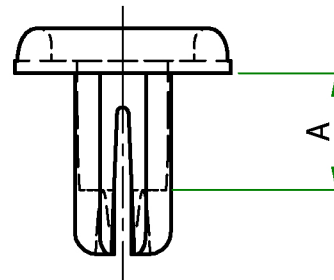

Item	Hole Size	Panel Thickness	A
RRR-2	4.76 - 5.28 Ø or 4.5 Min. Square	3.5 - 5.5	4.4

UNLESS OTHERWISE STATED

ALL DIMENSIONS IN mm

DO NOT SCALE

LINEAR TOLERANCE

THIRD ANGLE PROJECTION

SIZE	(0)	(0.0)	(0.00)
0-10mm	±0.5	±0.15	±0.10
10-30mm	±0.5	±0.20	±0.15
30-50mm	±0.5	±0.30	±0.20
50-100mm	±0.8	±0.50	±0.25
100-200mm	±1.5	±0.80	±0.40
200-300mm	±2.0	±1.20	±0.80
300-500mm	±3.0	±2.00	±1.00
+500mm	±5.0	±3.00	±1.50

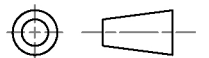

ANGULAR TOLERANCE ±0.5 DEGREES
UNSPECIFIED RADII 0.25mm
DRAFT ANGLE 0.5 DEGREES

ORG.SCALE 3:1

MATERIAL **BLACK NYLON**

ITEM No. **RRR-2**

TITLE **REMOVABLE RIVET**

DWG.No. **SRRRR-1**

ISSUE No. **1**