

标记	变更内容
①	16.50±0.50更新为: 16.50±0.30
②	4.00±0.50更新为: 3.50±0.30

版本变更			
版本	变更原因	变更人	日期
01	尺寸变更	许莎莎	2022.06.02

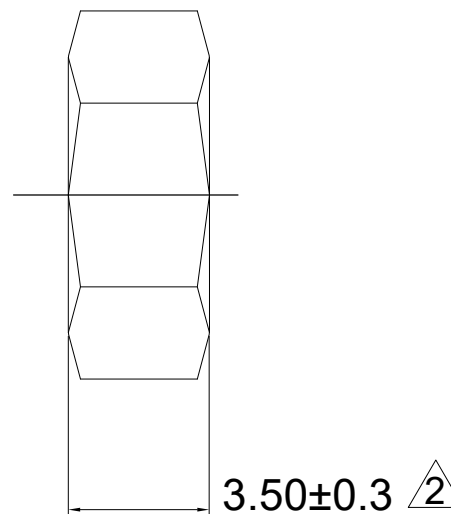
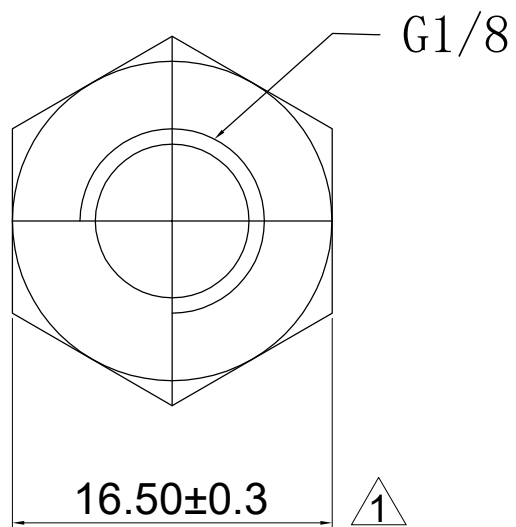

备注:

1. 材质: PE本色
1. 未注公差参考GB/T-1804M
2. ARJO PART NO: 675435
3. G1/8 螺纹过通规

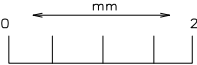
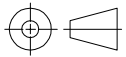
DIMENSIONAL TOLERANCES		SCALE: 1 : 1
.XX	±	0  20
.X	±	
ANGLES	±	 THIRD ANGLE PROJECTION

DO NOT SCALE DRAWING

TITLE: 六角螺母

PART NO: E041282

Description:

苏州艾奥珂电子有限公司